



An Original and exclusive design which adapts itself in aesthetic harmony to any building.

QubeLift, is excellent for reaching balconies and floor landings keeping in mind the architectural balances of the buildings.

# QubeLift

Platform Lift in open liftway





## Endurance and elegance in a single solution

Qubelift Platform with modern line features and high tech finishing integrates perfectly into any prestigious environments or surroundings.

Carefully designed and detailed lifting appliance made to suit comfort of use with aesthetics features, by using glazed surroundings, non invasive frames, rounded off aluminum edges and extensible hide away bellows.

Qubelift, combines practicality of use and easy accessibility thanks to its wide opening gate fitted with practical handrails, legible push button control panels indicators on board and at floor levels.

The technical solutions adopted by QubeLift guarantees fast and simple installation.

Qubelift needs minimum mural works by incorporating on the machine itself the control and command devices. .

Qubelift is suitable for indoor and outdoor environments.



### CE CONFORMITY TO EUROPEAN DIRECTIVES

Machinery Directive 2006/42/CE

E.M.C. European Directives 2004/108/CE

Technical Data	MOD P04H
Max Travel	2000 mm
Pit depth	215 mm (travel ≤1500 mm)
	255 mm (travel >1500 mm)
Platform dimension	1500 x 1120 mm
Net gate opening	900 mm
Gate / side panels height	1100 mm
Rated load	300 kg
Lifting Speed	2 m/min
	(0,03 m/sec)
Max. power consumptin	0,8 kW
Feeding Power	230 V Monophasic
IP Protection	IP55

*The environmental characteristics of the installation site will determine the feasibility and the machine type*



## Useful Information

### Basic execution of QubeLift mod. P04H

- Single wing manual gate in anti-crash glass, 90° outward opening.  
Net opening 900 mm, height 1100 mm.  
Upper landing access gate fitted on the floor.  
Lower landing access gate fitted on the platform  
Electromechanical lock with enabling signal to leave the floor only with shut and mechanically locked gate
- Glazed side panels made of anti-crash glass, height 1100 mm, to protect the free sides
- Extendable and hideaway bellow beneath the platform fitted with top sensitive anti-crushing safety edge
- Lateral guides mounted to the wall to prevent oscillation
- Constant pressure controls: Up / Down push buttons control panel on board integrated in the console; Wall mounted push button call controls with key activation at both landing levels
- Automatic Upper floor levelling device
- Emergency power failure lowering device with buffer battery
- Machine roomless: all control and command devices are integrated in the machine itself
- Finishing: structure and handgrips in light gray, platform surface covered in rubber or almond aluminum, transparent or smoked glass panels

- Environmental service conditions: -10°C / + 40°C for indoor or outdoor environment (not severe or extreme environmental conditions)

### QubeLift Optional

- Powered gates
- Posts for landing push button control panel
- Stainless steel execution
- Anti-vandal execution
- Customized finishing





## OVERALL DIMENSIONS

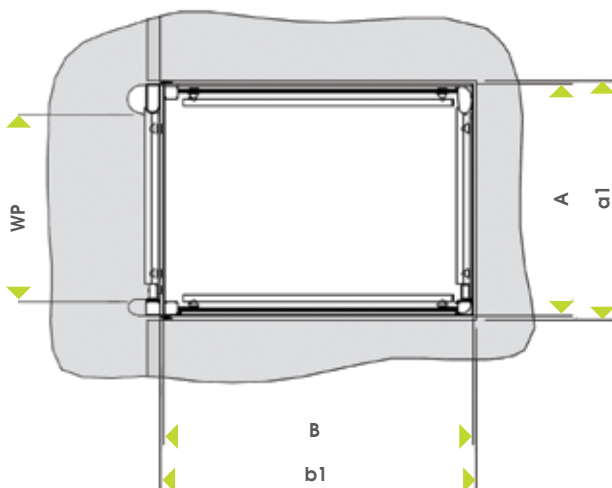
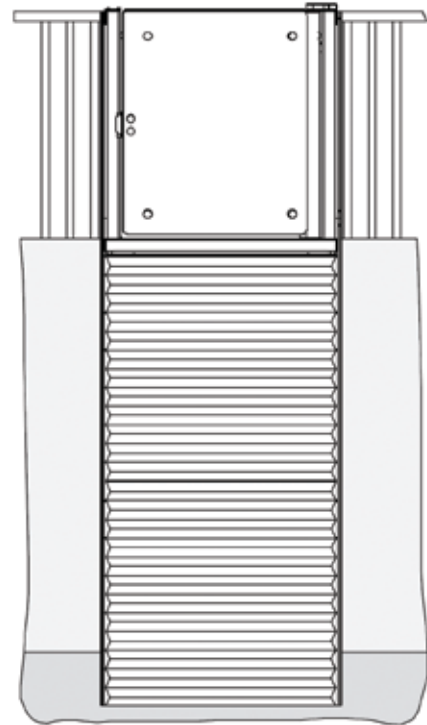
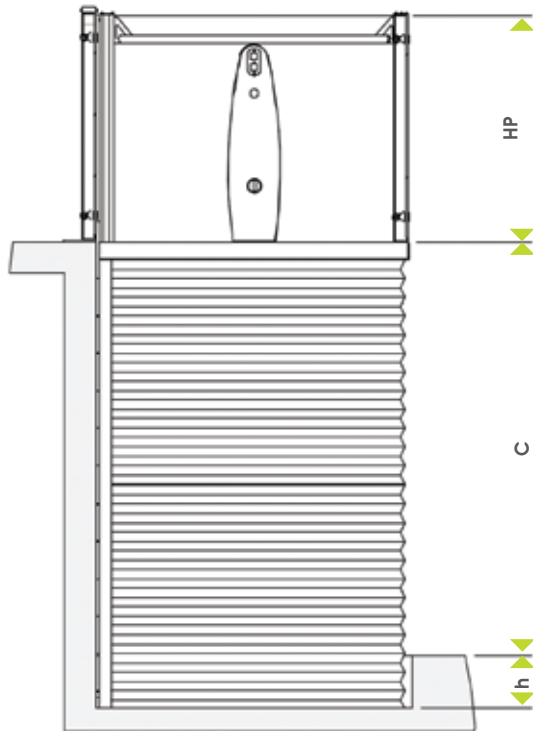

A	1120
a1	1160
B	1500
b1	1540
C	2000 max
h	215 (C ≤ 1500) 255 (C > 1500)
HP	1100
WP	905

## Dimension chart 1

### ENTRANCES / PIT

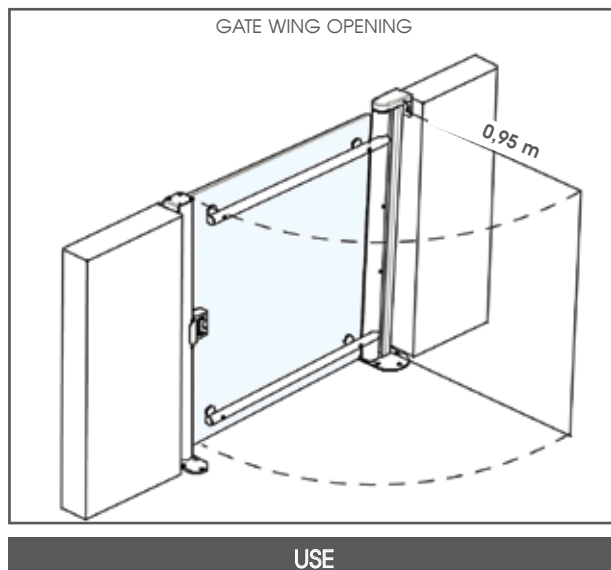
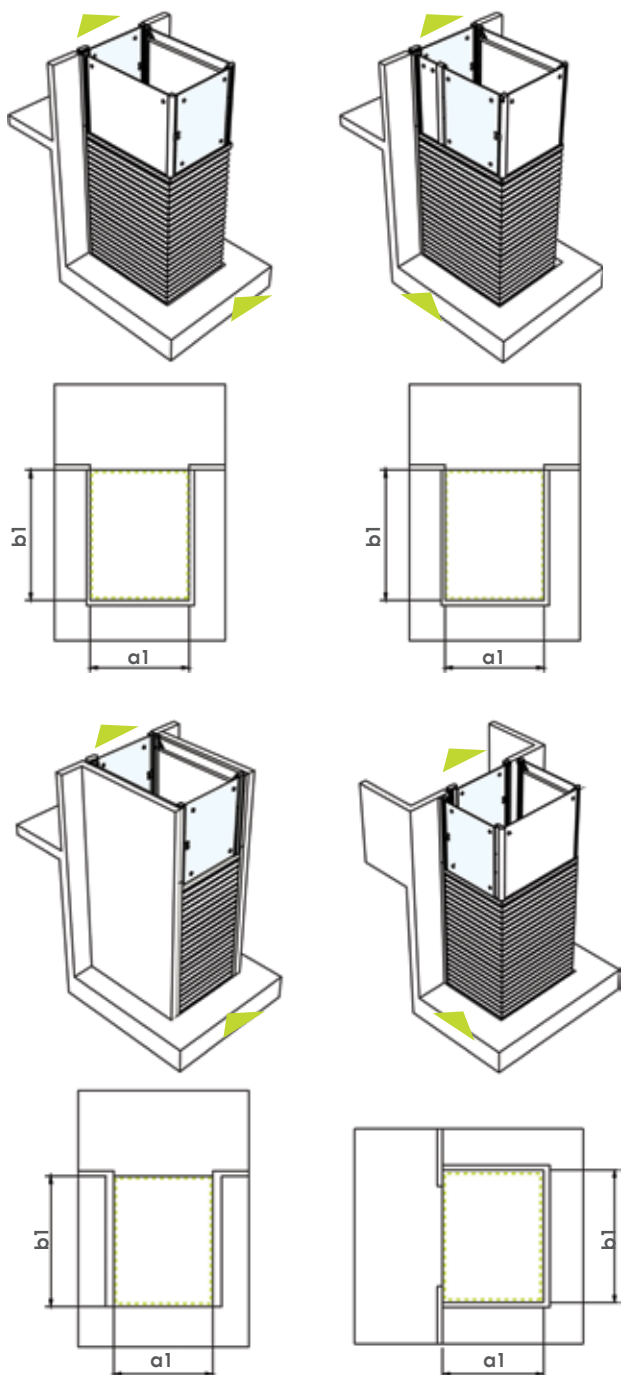

*Suggested maneuvering spaces with wheelchair*

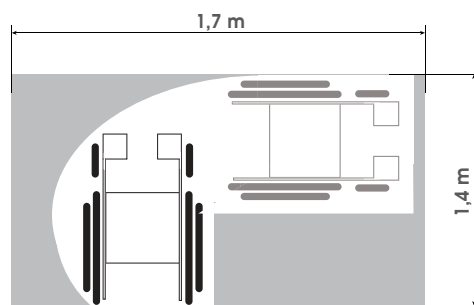

90° CURVE

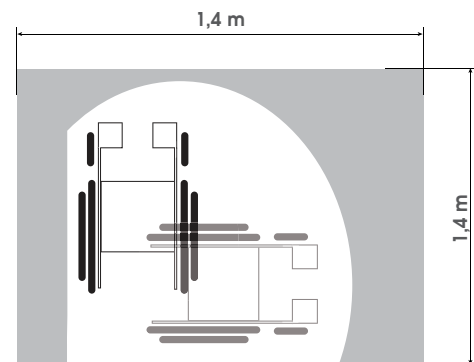

90° ROTATION

## Dimension chart 2

### REQUIREMENTS FOR THE INSTALLATION OF THE MACHINE

- Minimum suggested height of the walls adjacent to the platform: 1100 mm beyond the upper floor level
- All walls and and/or structures adjacent to platform, towards the liftway, must be smooth and continuous with no protruding or sharp edges. Protruding or sharp edges are acceptable as long as they are lower than 1,5 mm (if not rounded off Ex. 1), or lower than 5mm as long as if they rounded off at 15° in (Ex. 2) comparison to the vertical line.

ex. 1

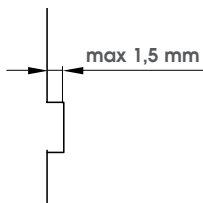

ex. 2

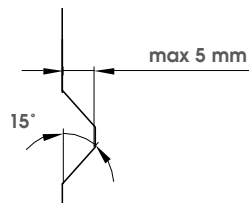

- The support area at the bottom of the pit must be even, compact and horizontal. The pit floor must be capable to support in safety the payload hereby indicated in the striped area.

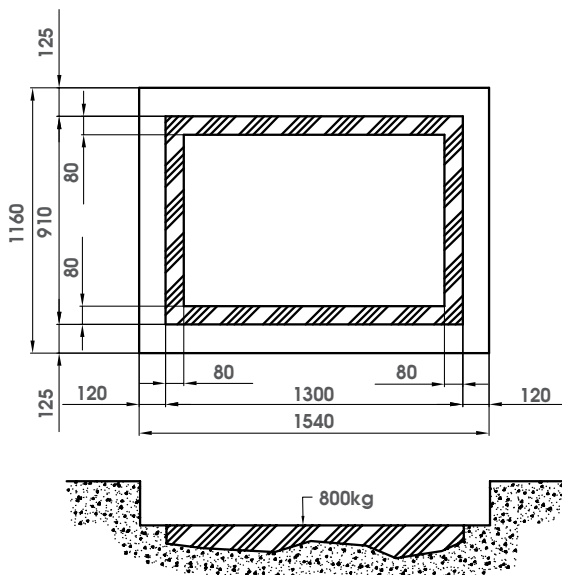

### CHECK OF THE SAFETY DISTANCES

Possible fixed structure (i.e. handrails) adjacent to the platform, if no smooth and continuous, can cause danger of shearing. If it is not possible to respect the minimum safety distances indicated below, it is necessary to realise, between the moving platform and the fixed parts, a smooth and continuous fixed panel having 1100 mm height beyond the upper floor level.

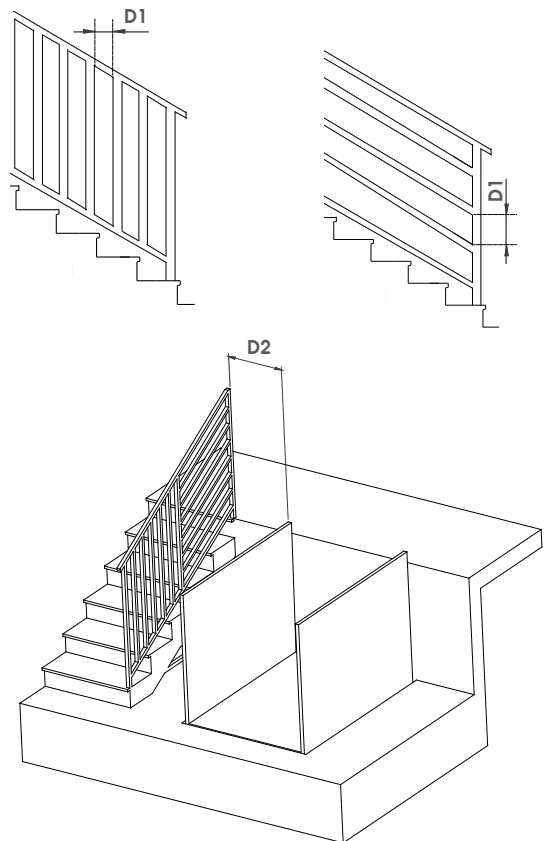

D1	D2	Fixed platform wall
< 10	//	opt
> 10 < 25	25	necessary
> 25 < 100	120	necessary
> 100	500	necessary

D2 Minimum platform distance from adjacent structures

## Dimension chart 2

### FLOOR LEVEL PUSH BUTTON CONTROLS

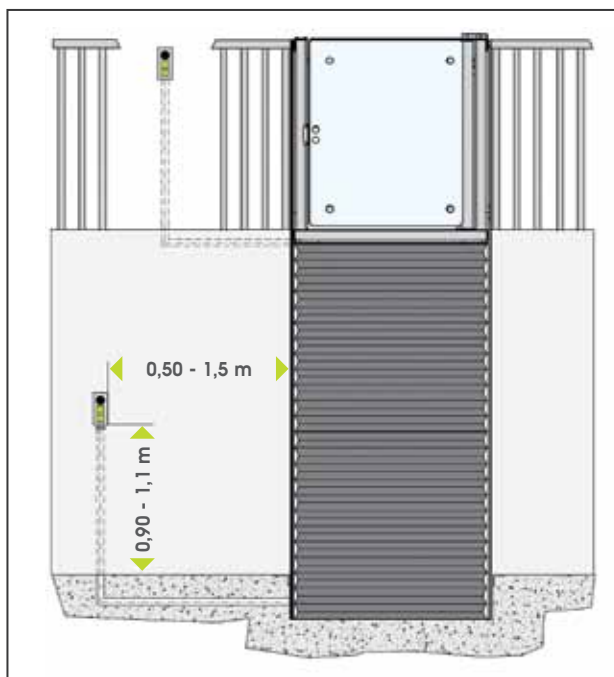

The position of the floor level landing controls must be placed in a way to allow highest visibility of the machine during the movement and must not clutter the area after it being used.

#### Suggested distance between 0,50 and 1,50 m:

The position of the floor level landing control must not interfere with the gate opening travel

#### Suggested height between 0,90 and 1,10 m:

The positioning of floor level landing controls must take into consideration a wheelchair user.

#### Push-button Control:

Dimensions: 65 x 80 x 170 mm

#### Push-button Control:

- *Lower floor:* Call push-button, key activation, key for emergency lowering of platform
- *Upper floor:* Call push-button and key activation

All controls relating to the movement of the platform lift are of the constant pressure type.

### PRE-ASSEMBLED PLATFORM

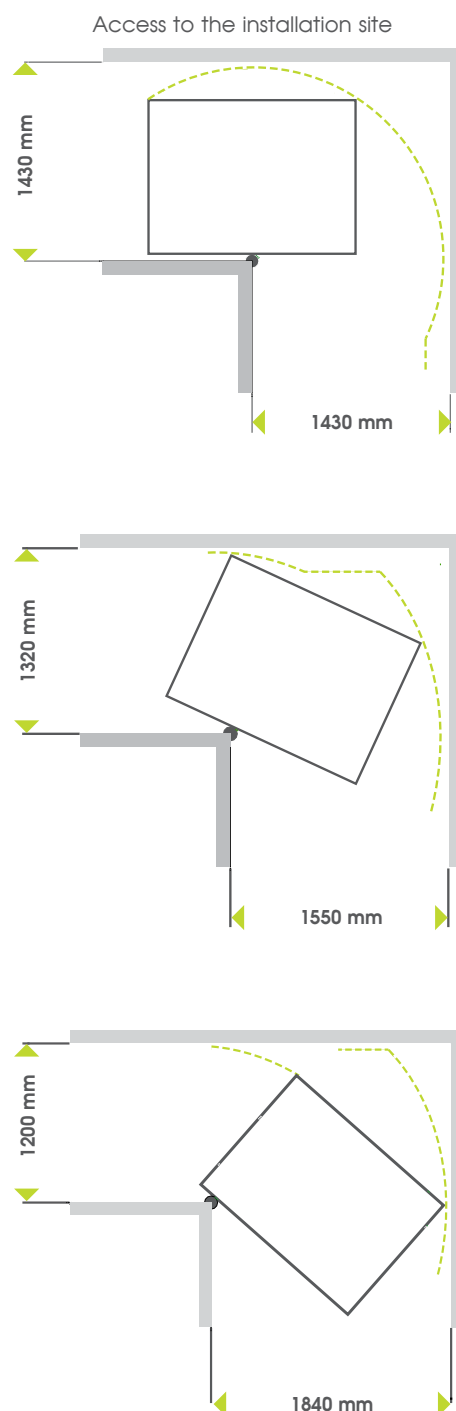

## Dimension chart 3 > Installation Site Preparation

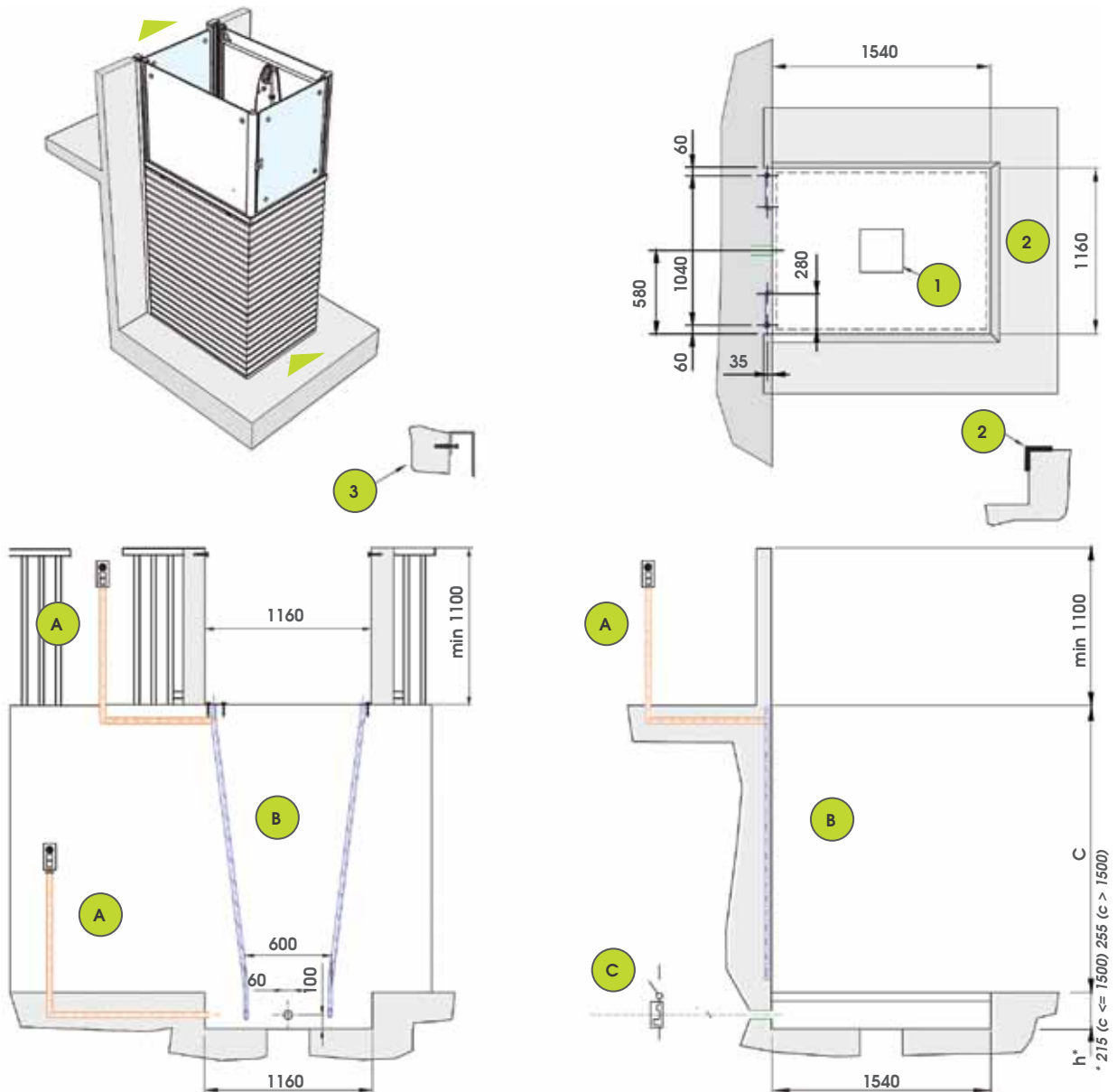

### Pit type A

- A - Connecting line for landing controls**  
The customer shall provide:
  - A cable for the connection of the upper push-button: 2 x 1mm<sup>2</sup>
  - A cable for the connection of the lower push-button: 4 x 1mm<sup>2</sup>
  - A tube passage for cables shall have a min. diameter of: 30mm
- B - Connection line for the upper landing gate:**  
The customer shall provide:
  - 2 cables: 5 x 1mm<sup>2</sup>
  - A tube passage for cables shall have a min. diameter of: 30mm

- C - Connecting to the electrical power line:**  
The customer shall provide a dedicated power line (INPUT Voltage 230 VAC), The power line shall be fitted with:
    - A thermal magnetic circuit breaker (10A Trip sensitivity 30mt, C trip curve)
    - A cable 3 x 1,5 mm<sup>2</sup> for the connection to the power unit (min. tube diameter to allow the cable passage: 30mm)
 Note: The line shall be fitted with a connection to earth  
Power consumption: 0,8 kw
- 1 For external installations a drainage outlet must be provided on the pit bottom
  - 2 Reinforcement corner frame to the pit edge
  - 3 The upper landing gate is not self bearing, it shall be fastened to the wall or handrail to ensure stability.



## Dimension chart 3 > Installation Site Preparation

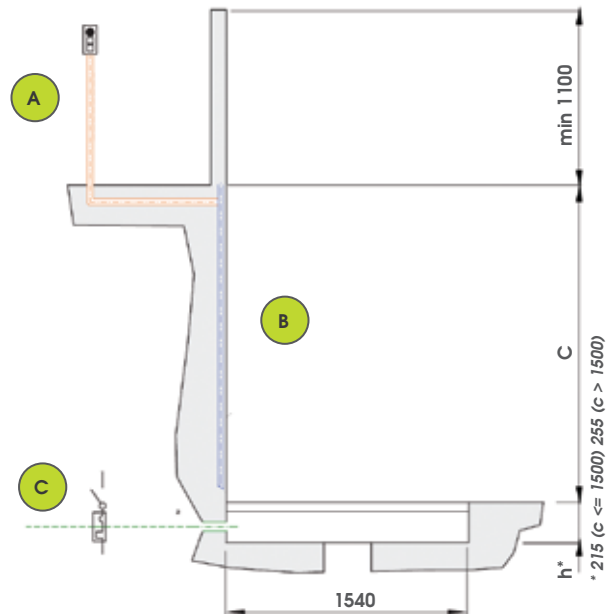
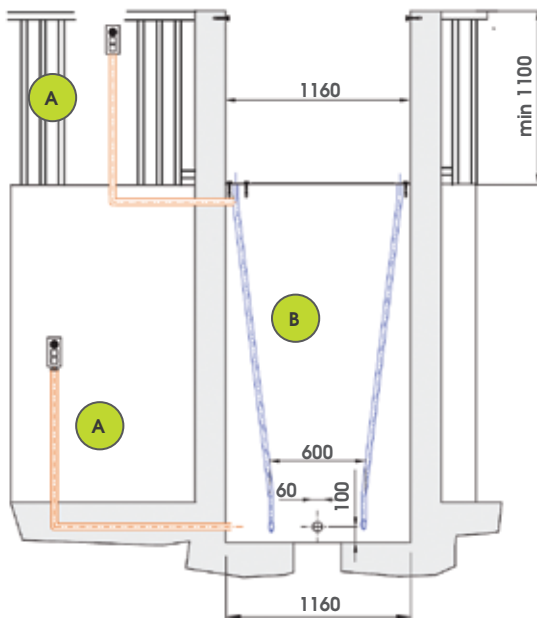
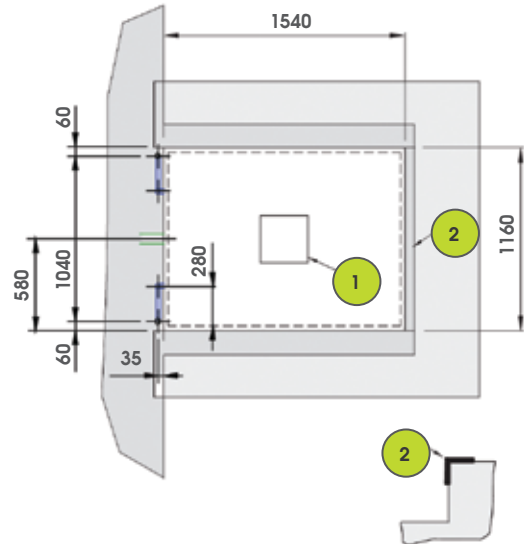
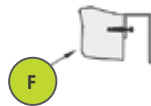
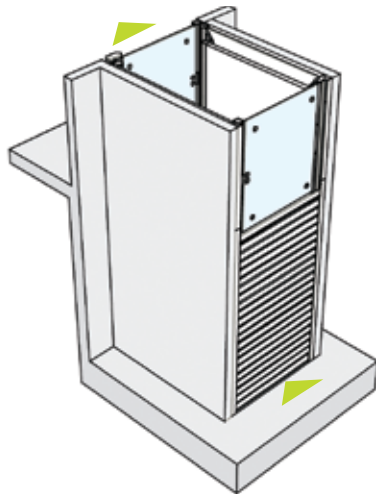

### Pit type B

#### A - Connecting line for landing controls

The customer shall provide:

- A cable for the connection of the upper push-button: 2 x 1mm<sup>2</sup>
- A cable for the connection of the lower push-button: 4 x 1mm<sup>2</sup>
- A tube passage for cables shall have a min. diameter of: 30mm

#### B - Connection line for the upper landing gate:

The customer shall provide:

- 2 cables: 5 x 1mm<sup>2</sup>
- A tube passage for cables shall have a min. diameter of: 30mm

#### C - Connecting to the electrical power line:

The customer shall provide a dedicated power line (INPUT Voltage 230 VAC), The power line shall be fitted with:  
 - A thermal magnetic circuit breaker (10A Trip sensitivity 30mt, C trip curve)  
 - A cable 3 x 1,5 mm<sup>2</sup> for the connection to the power unit (min. tube diameter to allow the cable passage: 30mm)  
 Note: The line shall be fitted with a connection to earth  
 Power consumption: 0,8 kw

- 1 For external installations a drainage outlet must be provided on the pit bottom
- 2 Reinforcement corner frame to the pit edge
- 3 The upper landing gate is not self bearing, it shall be fastened to the wall or handrail to ensure stability.

## Dimension chart 3 > Installation Site Preparation

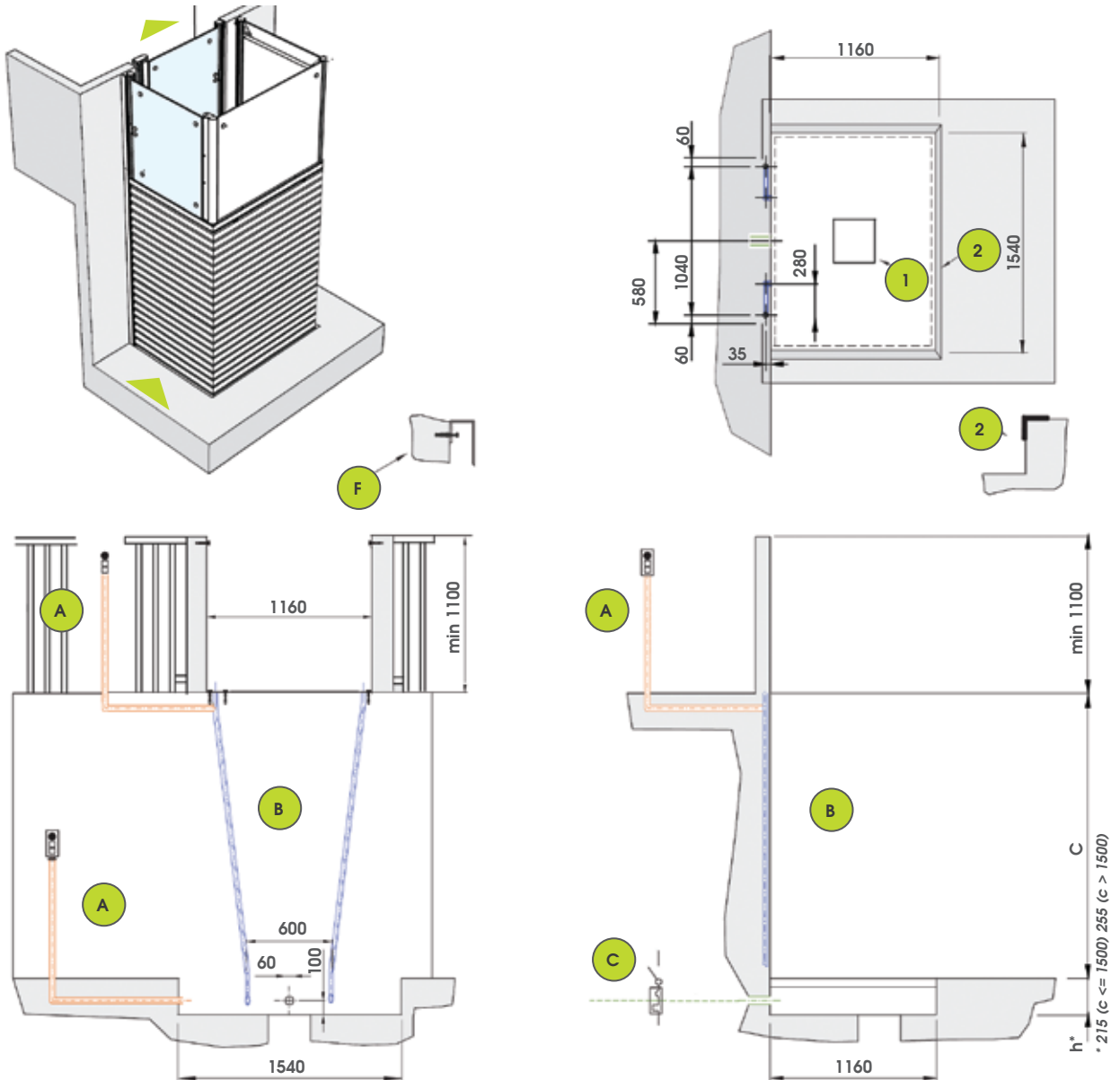

### Pit type C

- A - Connecting line for landing controls**  
The customer shall provide:
  - A cable for the connection of the upper push-button: 2 x 1mm<sup>2</sup>
  - A cable for the connection of the lower push-button: 4 x 1mm<sup>2</sup>
  - A tube passage for cables shall have a min. diameter of: 30mm
- B - Connection line for the upper landing gate:**  
The customer shall provide:
  - 2 cables: 5 x 1mm<sup>2</sup>
  - A tube passage for cables shall have a min. diameter of: 30mm

- C - Connecting to the electrical power line:**  
The customer shall provide a dedicated power line (INPUT Voltage 230 VAC). The power line shall be fitted with:
    - A thermal magnetic circuit breaker (10A Trip sensitivity 30mt, C trip curve)
    - A cable 3 x 1,5 mm<sup>2</sup> for the connection to the power unit (min. tube diameter to allow the cable passage: 30mm)
 Note: The line shall be fitted with a connection to earth  
Power consumption: 0,8 kw
- 1 For external installations a drainage outlet must be provided on the pit bottom
  - 2 Reinforcement corner frame to the pit edge
  - 3 The upper landing gate is not self bearing, it shall be fastened to the wall or handrail to ensure stability.

## Dimension chart 3 > Installation Site Preparation

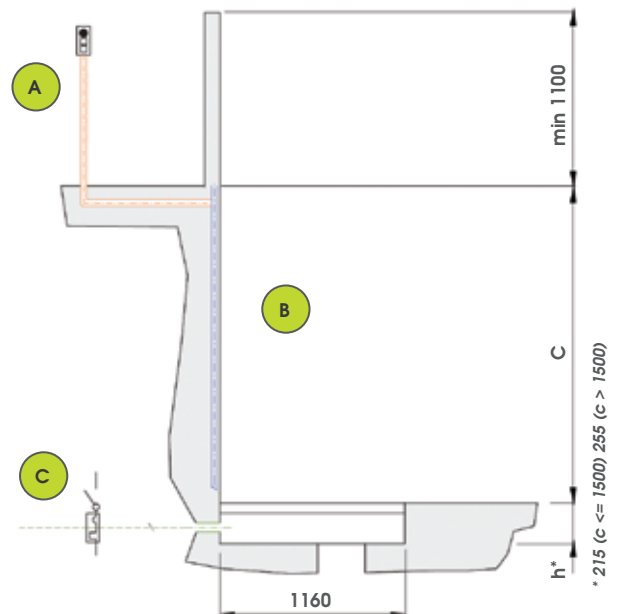
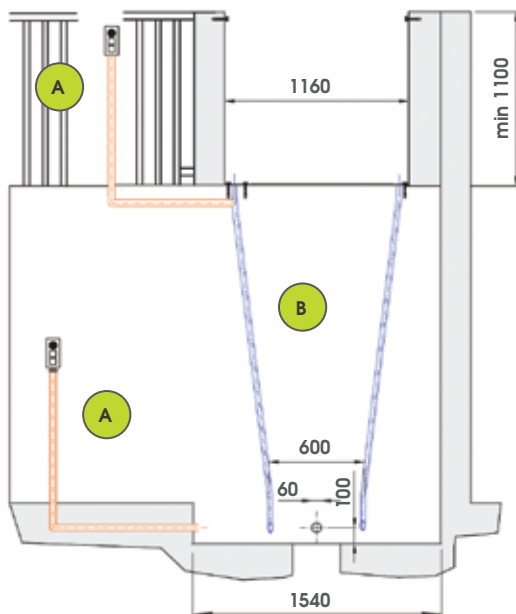
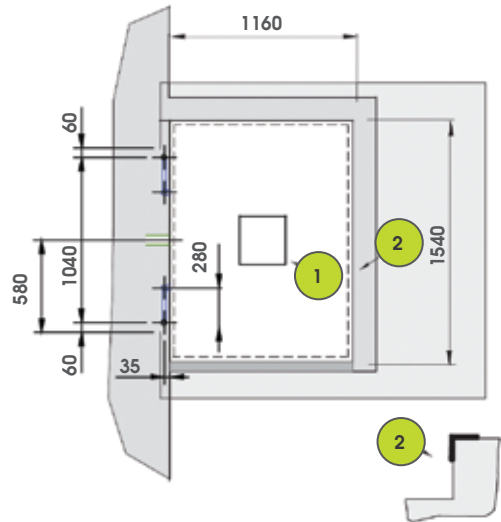
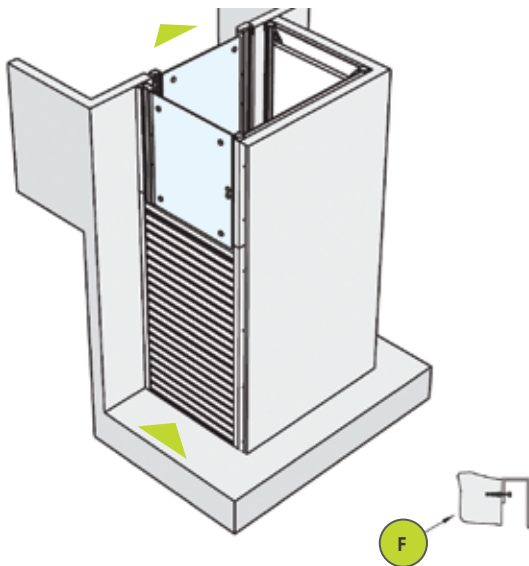

### Pit type D

#### **A - Connecting line for landing controls**

The customer shall provide:

- A cable for the connection of the upper push-button: 2 x 1mm<sup>2</sup>
- A cable for the connection of the lower push-button: 4 x 1mm<sup>2</sup>
- A tube passage for cables shall have a min. diameter of: 30mm

#### **B - Connection line for the upper landing gate:**

The customer shall provide:

- 2 cables: 5 x 1mm<sup>2</sup>
- A tube passage for cables shall have a min. diameter of: 30mm

#### **C - Connecting to the electrical power line:**

The customer shall provide a dedicated power line (INPUT Voltage 230 VAC). The power line shall be fitted with:

- A thermal magnetic circuit breaker (10A Trip sensitivity 30mt, C trip curve)
  - A cable 3 x 1,5 mm<sup>2</sup> for the connection to the power unit (min. tube diameter to allow the cable passage: 30mm)
- Note: The line shall be fitted with a connection to earth  
Power consumption: 0,8 kw

- 1 For external installations a drainage outlet must be provided on the pit bottom
- 2 Reinforcement corner frame to the pit edge
- 3 The upper landing gate is not self bearing, it shall be fastened to the wall or handrail to ensure stability.

### **Manufacturing and Premises**

SITES SRL

Via Cavalieri di Vittorio Veneto

23870 Cernusco Lombardone - LC (Italy)

Tel +39 039 999 18.1

Fax +39 039 999 18.55

info@sites.it

Data, technical features and finishing are non-binding and may change without notice.



by **SITES**  
**FreeLifeSTYLE**  
[www.freelifestyle.eu](http://www.freelifestyle.eu)